

LEVEL -8

PHYSICS

FINAL TERM REVISION WORKSHEET -3

TOPIC : PROPERTIES OF WAVES & SPECTRA

SECTION A

MULTIPLE CHOICE QUESTIONS

1. The diagram represents a wave.

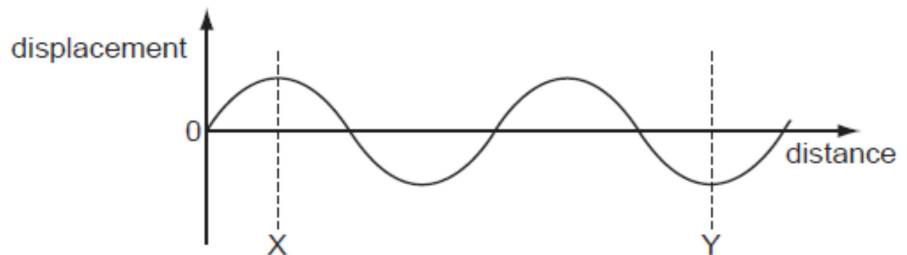

How many wavelengths are there between X and Y?

- A** $\frac{2}{3}$ **B** 1 **C** $1\frac{1}{2}$ **D** 3
2. Which group contains only transverse waves?
- A. infra-red waves, light waves, sound waves
 - B. infra-red waves, light waves, ultra-violet waves
 - C. infra-red waves, ultra-violet waves, sound waves
 - D. light waves, sound waves, ultra-violet waves
3. Waves in a tank pass from shallow to deep water. The wave-front diagram is shown.

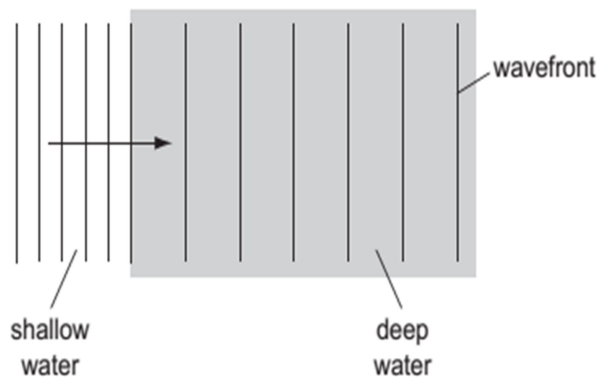

Which quantity increases as the waves enter the deep water?

- A. amplitude
- B. frequency
- C. wave energy
- D. wavelength

4. Different parts of the electromagnetic spectrum are used for different purposes. Below are four statements about parts of the spectrum.

statement 1: Infra-red waves are used in television remote controllers.

statement 2: Radio waves are used to transmit television pictures from satellites to Earth.

statement 3: Ultra-violet waves are used for intruder alarms.

statement 4: X-rays are used for security checks.

Which statements are correct?

- A** 1 and 2 **B** 1 and 4 **C** 2 and 3 **D** 3 and 4

5. A vertical stick is dipped up and down in water at P. In two seconds three wave crests are produced on the surface of the water.

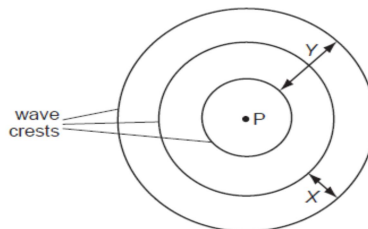

Which statement is correct?

- A. Distance X is the amplitude of the waves.
- B. Distance Y is the wavelength of the waves.
- C. Each circle represents a wave-front.
- D. The frequency of the waves is 3 Hz.

6. The diagram shows water waves passing through a gap in a harbour wall. The waves curve round the wall and reach a small boat in the harbour.

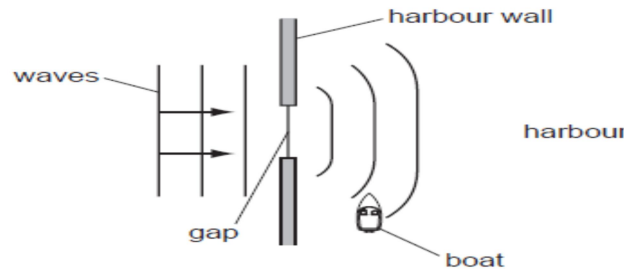

What is the name of this curving effect, and how can the gap be changed so that the waves are less likely to reach the boat?

	name of effect	change to the gap
A	diffraction	make the gap slightly bigger
B	diffraction	make the gap slightly smaller
C	refraction	make the gap slightly bigger
D	refraction	make the gap slightly smaller

7. Which row correctly describes light waves and radio waves?

	light waves	radio waves
A	longitudinal	longitudinal
B	longitudinal	transverse
C	transverse	longitudinal
D	transverse	transverse

8. A boy throws a small stone into a pond. Waves spread out from where the stone hits the water and travel to the side of the pond. The boy notices that eight waves reach the side of the pond in a time of 5.0 s. What is the frequency of the waves?

- A. 0.20 Hz B. 0.63 Hz C. 1.6 Hz D. 40 Hz

9. Water waves can be used to show reflection, refraction and diffraction. For each of these, which row shows whether or not the speed of the water waves changes?

	reflection	refraction	diffraction
A	no	no	yes
B	no	yes	no
C	yes	no	no
D	yes	yes	yes

10. The table gives common uses for three types of electromagnetic wave. Which row correctly identifies the waves?

	satellite television	terrestrial television (not satellite)	television remote controllers
A	infra-red waves	microwaves	radio waves
B	microwaves	radio waves	infra-red waves
C	radio waves	infra-red waves	microwaves
D	radio waves	microwaves	infra-red waves

11. The diagram shows plane waves reflected by a plane surface. Which line represents a wavefront?

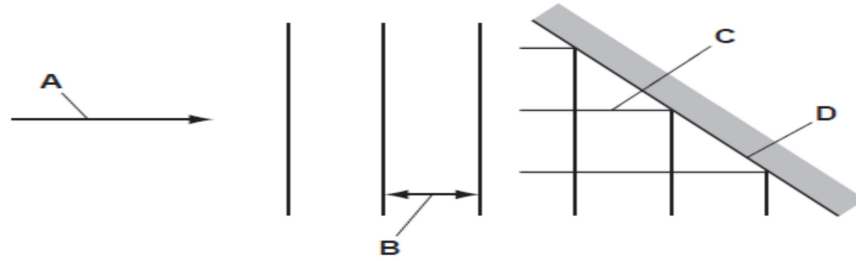

12. Which waves are longitudinal?



light waves from a lamp



microwaves in an oven



sound waves from a trumpet

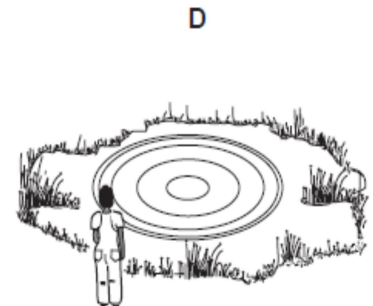

water waves on a pond

13. A swimmer is sitting on a rock at the sea shore looking at passing waves. He notices that five complete wavelengths pass him in 20 s. What is the frequency of this wave?

A. 0.25 Hz

B. 4.0 Hz

C. 15 Hz

D. 100 Hz

14. The diagrams show water waves that move more slowly after passing into shallow water at the broken line. Which diagram shows what happens to the waves?

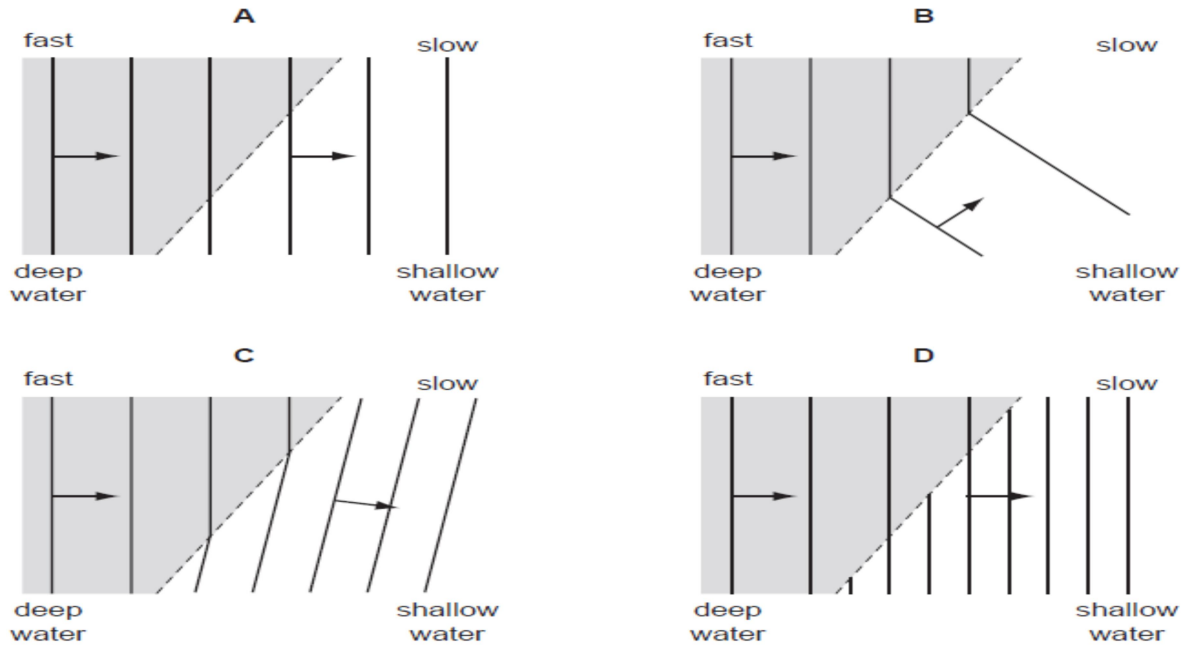

15. Radio waves are received at a house at the bottom of a hill.

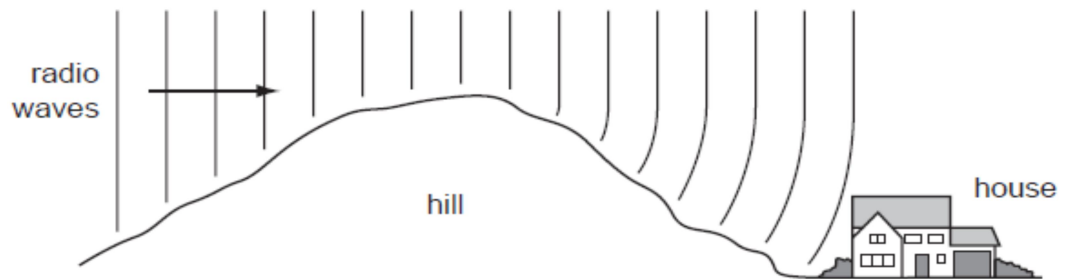

The waves reach the house because the hill has caused them to be

- A. diffracted.
- B. radiated.
- C. reflected.
- D. refracted.

16. The diagrams show examples of wave motion.

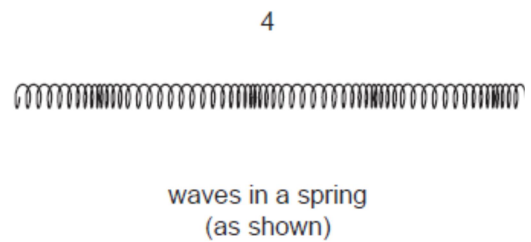
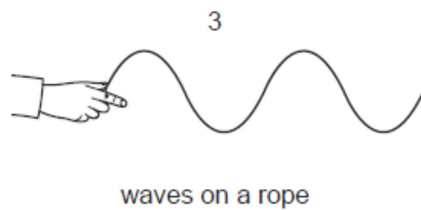
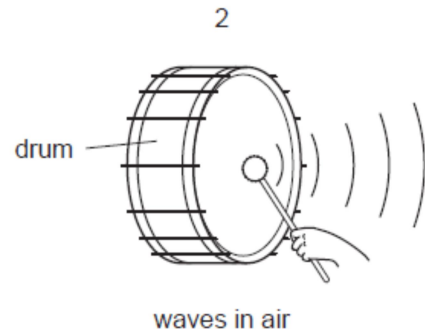
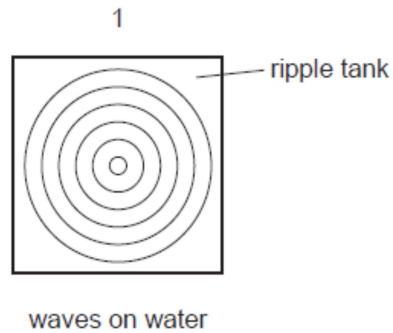

Which are longitudinal waves?

- A 1 only
- B 1, 2 and 4
- C 2 and 3 only
- D 2 and 4 only

17. A small boat in a harbour is protected from waves on the sea by harbour walls.

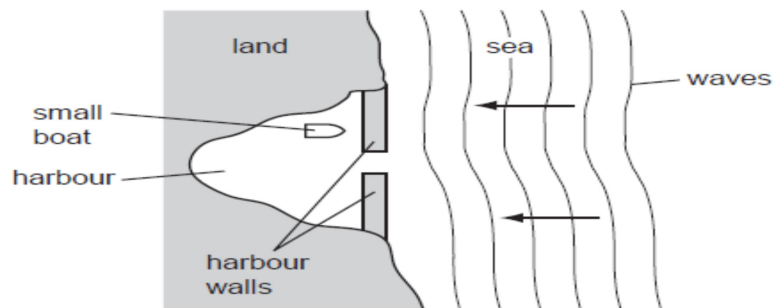

Some waves can curve round the harbour walls and reach the boat.

What is the name for this effect?

- A diffraction
- B dispersion
- C reflection
- D refraction

18. The diagram shows the dispersion of white light by a glass prism.

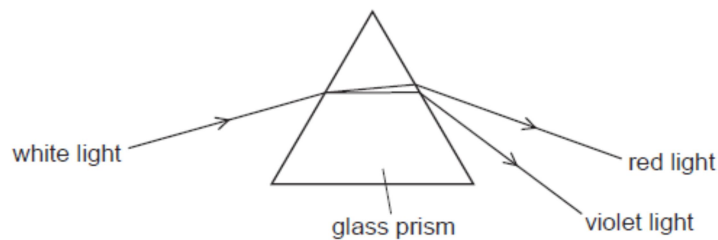

Why does dispersion occur when white light enters the glass?

- A The frequency of red light decreases more than that of violet light.
- B The frequency of violet light decreases more than that of red light.
- C The speed of red light decreases more than that of violet light.
- D The speed of violet light decreases more than that of red light.

19. Which diagram shows what happens when a ray of white light passes through a prism?

